



www.girbau.com

GIRBAU

LAUNDRY EQUIPMENT

**FT SERIES
FOLDERS**

FT-LITE
FT-MAXI
FT-POLY
FT-VEST

Independent folders. A folder for every requirement

A FOLDER FOR EVERY REQUIREMENT

FT SERIES



A folder is a highly important item in a laundry. On the one hand it is the final point for all the processes, and must maintain the same level of quality as that obtained during washing, drying and ironing.

On the other, it provides the final impression given by the items.

This is why Girbau has developed a wide range of folding machinery, because every laundry has its particular standards of quality and its requirements; and because the folder is not just another step, but rather the touch that provides the final finishing.

With the FT folder series, Girbau has created a range capable of folding any type of article with efficiency and quality, adapting to the demands of each particular laundry.

The size of the laundry items, the type of fold, the material, the level of quality ... each laundry is a world in itself and each world finds an answer with the FT Series.

With the FT folders, Girbau reinforces its Easy & Best Solutions philosophy: creating flexible laundry solution packages that are adapted to any sector, so that each customer can easily find the solution they are looking for in terms of laundry products and services.





ECONOMY AND SIMPLICITY IN A COMPACT FORM

FT-LITE



The FT-LITE is designed for folding towels and other articles of towelling, airline blankets and similar items. In addition, it accepts everything from small articles to large-scale items (1,200mm x 2,400mm).



The FT-LITE folder (compact and with wheels)



The LITE range is Girbau's simple and economic answer to folding requirements. Good solutions do not have to be complicated or expensive.

Simplicity of operation, low maintenance and an affordable price. These are the features of the new Girbau LITE line of finishing machinery, designed for laundries where reliability, productivity and profitability are priority factors.

PRIMARY FOLD

The FT-LITE performs 1, 2 and even 3 longitudinal folds. The longitudinal fold can be configured for folding the article in half (1/2) or for a French type fold (1/3).

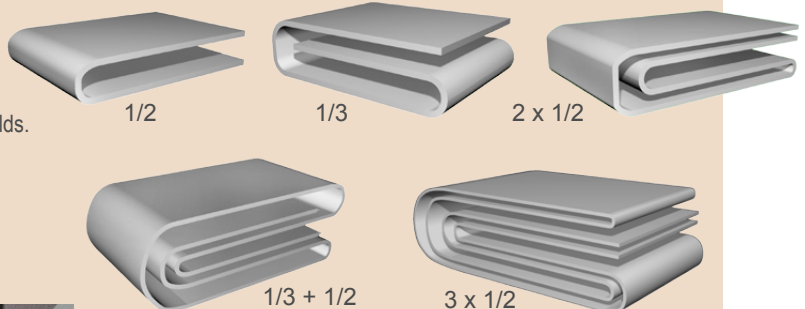

SECONDARY FOLD AND STACKING

The FT-Lite folder can perform a secondary half cross fold with a rotary stacker (stack & fold). This fold is compulsory.

The items return from the stacker to the operator on a discharge belt.

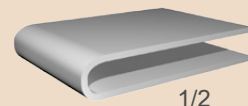

TECHNOLOGY

MANUAL FEEDING

The feeding is performed manually on the feeding table. The table is fitted with indicators that aid in centring the item.



PRIMARY FOLDING WITH BLOWING SYSTEM AND BELT REVERSING

In the first 2 cross folds, reversal and a blowing system are used, while the final fold is performed with reversal and blade.

These folds are carried out without stopping the belts, thereby achieving an optimum treatment of the linen and a high productivity.



SECONDARY FOLD WITH STACKER (STACK & FOLD)

The secondary half fold is performed with a rotary stacker (stack & fold). The piles return from the stacker to the operator position on a discharge belt.



EASY TO USE TOUCH SCREEN GRAPHIC CONTROL

The FT-LITE incorporates an easy to use touch screen control system in colour, together with the basic operating programs.



PRODUCTIVITY

The technology applied in the FT-LITE ensures high productivity. Production can reach over 1000 items per hour, depending on type of article introduced, the type of folding and the skill of the operator.



QUALITY AND PRODUCTIVITY AT JUST THE RIGHT PRICE

FT-MAXI



MORE FEATURES, LESS SPACE

The FT-MAXI is a multiuse folder designed for folding, classifying and stacking items of towelling or similar.



The FT-MAXI folder can fold items of up to 1200 x 2350 mm.

VERSATILE AND MULTIUSE: DESIGNED WITH YOUR BUSINESS IN MIND

The compact design of the FT-MAXI allows you to make the most of its multiuse features, since it allows a mixture of different sized articles to be inserted while taking up very little room in your laundry (less than 4 metres).

PRIMARY FOLD

A blowing system is used for the primary fold, with an air jet that is adjusted to match the size of the article. It can perform 1 fold (in half) or 2 folds (French or 1/3 type).

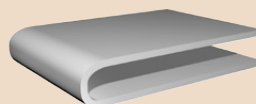

1/2

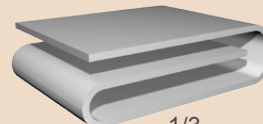

1/3

SECONDARY FOLD

A conveyor reversing system, together with a powerful air jet, allows 1 or 2 cross folds to be performed.

The belts used in the cross folding are elastic, contributing to a quality folding and aiding access to the articles in the event of jamming.

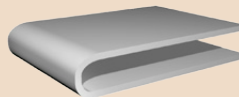

1/2

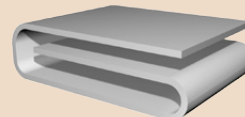

1/3



2 x 1/2

STACKING

The FT-MAXI automatically selects the laundry items and stacks them into three categories (up to four with the 4 stacker option), using stacking flaps.

The system includes a discharge conveyor that can be configured with its output to the left or right and in a forward or backward direction, according to the requirements.

A sloping conveyor delivers the piles of linen at a height that is accessible for the operator.

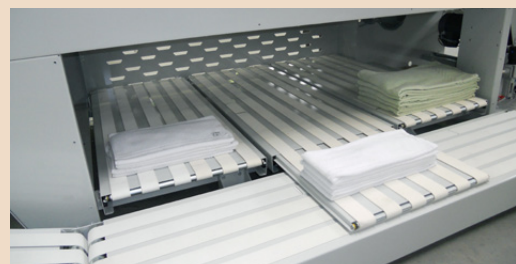

TECHNOLOGY

FEEDING TABLE INDEPENDENT

This folder is fed manually on an independent feeding table. The conveyors halt to allow the operators to feed in the linen, without affecting the production. In this way good quality feeding is assured.

The table is also fully ergonomic and height adjustable. Ergonomics and safety are omnipresent in the FT-MAXI.



PRIMARY FOLDING WITH EXCLUSIVE BLOWING SYSTEM

An air jet blowing system allows small and medium-sized articles to be folded without halting the conveyor, thus improving productivity without reducing folding quality.

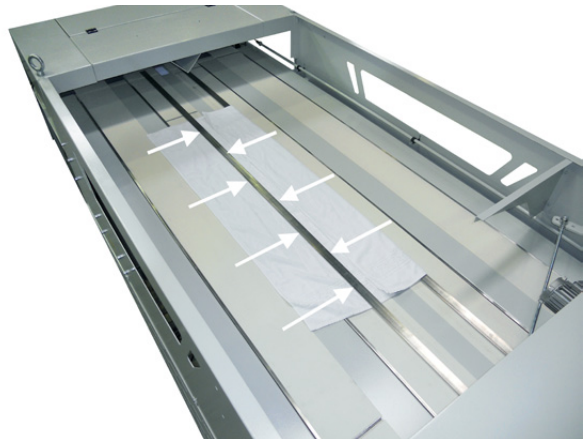

SECONDARY FOLDING USING REVERSING BELTS AND BLOWING

The elastic belts that perform the cross folding are extremely adherent, providing a high folding quality while allowing items to be easily extracted should jamming occur.



EASY TO USE TOUCH SCREEN GRAPHIC CONTROL

The FT-MAXI folder incorporates a control and programming system. A system of easy to use icons that guide the user in operating the machine.

All Girbau machines incorporate this control, helping operators to learn and develop a range of skills in handling the different equipment.



OPTIONS

The FT-MAXI is available with 4 stackers (1 additional to the standard machine) and the discharge conveyor can operate to the right or to the left.

600 mm wide stackers are available optionally.

PRODUCTIVITY

The FT-MAXI's reliability means high productivity. According to the size of the items, production can reach up to 1,200 pieces /hour, depending on the type of article inserted, the type of folding and the operator's skill.



MAXIMUM QUALITY AND OPTIMUM TREATMENT OF THE LAUNDRY ITEMS

FT-POLY



The FT-POLY is a multiuse folder designed for classifying, folding and stacking items of towelling, napkins, bath mats, bath towels, hospital gowns and small flat articles.



The design of the FT-POLY offers you maximum ease of use. The numerous possibilities for folding and stacking allow you to obtain greater production with optimum profitability.

The FT-POLY can fold and stack articles with sizes (width x length) ranging from 180 x 235 mm to 410, 580 mm.

MODULARITY AND MULTI USE: DESIGNED TO MEET YOUR REQUIREMENTS

INTRODUCTION

The articles can be fed in without classifying. The folding table automatically adjusts to the width of the articles inserted.

PRIMARY FOLD (V1 & V2)

The primary fold is performed using flaps. The article is held on the table by suction.

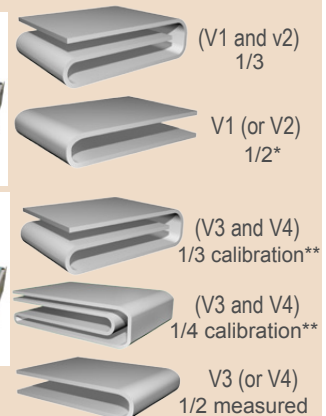
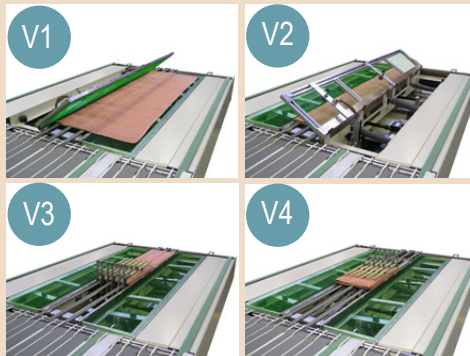

SECONDARY FOLD (V3 and V4)

The secondary fold is also performed using flaps. The article is held on the table by suction.

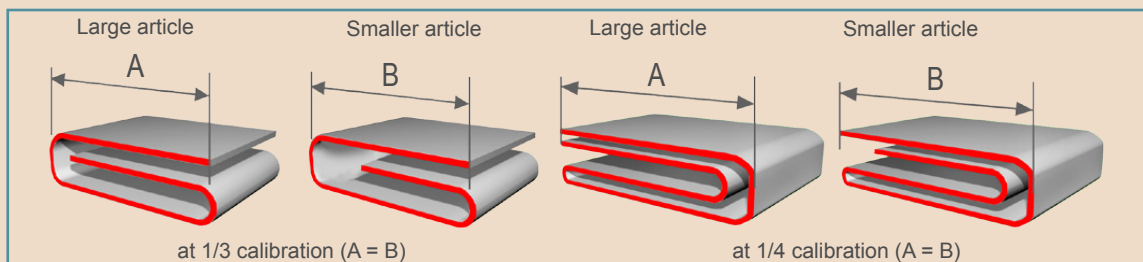

*Folded in half (1/2), the operator inserts the article with its centre lined up with the centre of the V1 or V2 flap hinge.

**The largest article determines the width.

STACKING

The stacking is performed by the automatic lifters that level out and press the articles that are already stacked and selected according to the sizes of the items. This pressing provides top quality stacking.

TECHNOLOGY

FEEDING TABLE

The items can be fed in without classifying. The folding table adjusts automatically to the width of the articles. Feeding can be performed manually or using a pedal. The suction incorporated into the belts holds the articles in position.

FOLDING TABLE WITH FLAPS

This technology (4 folding flaps combined with a suction system) makes it possible to obtain excellent folding quality. The folding table is 1,500 mm long. The width and the type of folding are adjusted automatically according to the dimensions of the article being inserted. The number and order of the flaps, widths, preceding and subsequent calibrations or folds, are adjustable and programmable parameters.

SELECTING AND STACKING THE ARTICLES

The articles are folded and stacked automatically according to category and size, and then deposited in the lifting trays (from 1 to 4). Each stack of linen is pressed and expelled.

EXTRACTING AND STORING THE PILES

There are as many methods of extraction as there are stackers available. The piles are collected at each stacker's discharge point to the right or to the left. The extracting is performed on independent belts (standard) or one common belt (optional).

OPTIONS

COMMON STACKER DISCHARGING (ftp.01)

This option includes a common collecting belt plus a sloping conveyor which places the folded articles at a height where they can be comfortably collected.

INDIRECT FEEDING TABLE WITH PRE-FOLDING (ftp.02)

The indirect table aids the insertion of items. The pre-folding (V5) is performed by a flap located at the entrance to the folding table. This flap allows the bottom of long articles, such as trousers, to be folded. It is fitted just before the main folding table, is 1,500 mm long, and can fold articles of up to 1,800mm in length.

PRODUCTIVITY

The FT-POLY produces up to 1,000 items/hour or 1,200 items/hour with a direct feeding table, depending on the type of articles treated and on the skill of the operator.

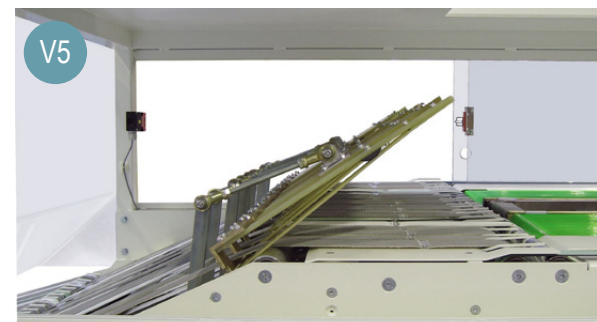
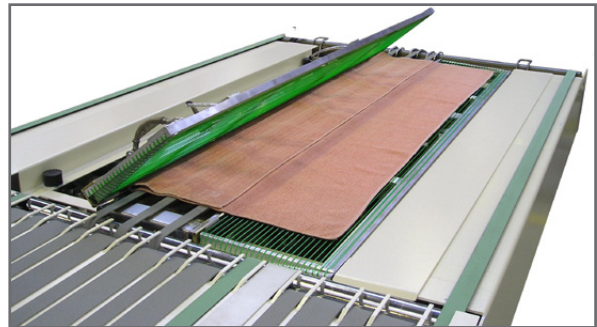

VERSATILITY AT THE SERVICE OF GARMENT

FT-VEST



The FT-VEST is a multipurpose folder designed to classify, fold and stack articles of towelling, napkins, bath mats, bath towels and small flat items.



The design of the FT-VEST offers you maximum ease of use. The numerous possibilities for folding and stacking allow you to obtain greater production with optimum profitability.

The FT-VEST can fold and stack articles with sizes (width x length) ranging from 180 x 235 mm to 410, 580 mm.

MODULARITY AND MULTI USE: DESIGNED TO MEET YOUR REQUIREMENTS

INTRODUCTION The articles can be fed in without classifying, in a vertical position on the suction conveyor.

SLEEVE FOLDER



PRIMARY FOLD (V1 & V2)

The primary fold is performed using flaps. The article is held on the table by suction during the folding operation.

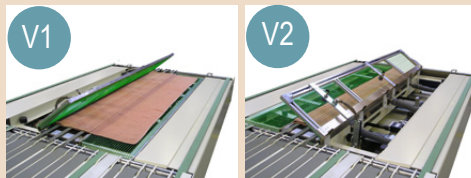

SECONDARY FOLD (V3 and V4)

The secondary fold is also performed using flaps. The article is held on the table by suction during the folding operation.

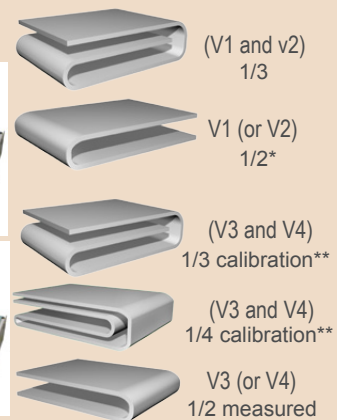
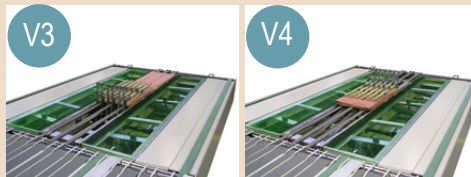

*Folded in half (1/2), the operator inserts the article with its centre lined up with the centre of the V1 or V2 flap hinge.
**The largest article determines the width.

STACKING

The stacking is performed by the automatic lifters that level out and press the articles that are already stacked and selected according to the sizes of the items. The piles of finished linen are expelled to the right or to the left, towards the operator, or optionally, in the opposite direction.

TECHNOLOGY

TOP FEEDING BELT WITH SUCTION

The items can be fed in without classifying. The top belt with automatic suction allows the operator to position the linen perfectly before inserting it. The feeding is validated by means of a button.

RETURN HEADSTOCK WITH SLEEVE FOLDING

The upper headstock allows the laundry item to be turned over in order to be folded in the front position. It also performs sleeve folding.

FOLDING TABLE WITH FLAPS

This technology (4 folding flaps combined with a suction system) makes it possible to obtain excellent folding quality. The folding table is 1,500 mm long. The width and the type of folding are adjusted automatically according to the dimensions of the article.

SELECTING AND STACKING THE ARTICLES

The articles are folded and stacked automatically according to category and size, and deposited in the lifting trays (1-4). Each stack of linen is pressed and expelled.

EXTRACTING AND STORING THE PILES

There are as many methods of extraction as there are stackers available. The piles are collected at each stacker's discharge point to the right or to the left. The extracting is performed on independent belts (standard) or one common belt (optional).

OPTIONS

COMMON STACKER DISCHARGING (ftv.01)

This option includes a common collecting belt plus a sloping belt which places the folded articles at a height where they can be comfortably collected.

INDIRECT FEEDING TABLE WITH PRE-FOLDING V5 (ftv.09)

Allows towels to be fed into the FT-VEST via an indirect table positioned in the opposite direction to the garment feeding conveyor. The indirect table aids the insertion of items.

The pre-folding (V5) is performed by a flap located at the entrance to the folding table.

AN ADDITIONAL TABLE FOR INSERTING TOWELS WITH DIRECT FEEDING (ftv.06)

This option allows towels to be fed into the FT-VEST via an indirect table positioned in the opposite direction to the garment feeding belt.

PRODUCTIVITY

The FT-VEST produces up to 800 pieces/hour, inserting garments, and up to 1,200 articles/hour inserting towels on the additional table (optional).

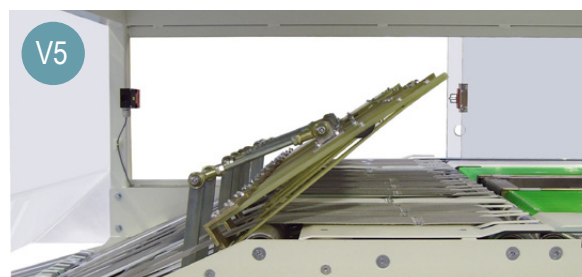

MODEL		FT-LITE	FT-MAXI	FT-POLY	FT-VEST
ELECTRICITY					
Installed power	kVA	2	2,5	6,5	7,3
400V 3ph connection		3 X 2,5 mm ² +T+N	3 x 2,5 mm ² + T	3 X 4 mm ² +T	3 X 4 mm ² +T
COMPRESSED AIR					
Supply pressure	bar	6 a 10	6 a 10	6	6
Consumption/hour per 100 items	Nm ³	4 / 100 pzas	1-2 / 100 pzas	3 / 100 pzas	4 / 100 pzas
OTHERS					
Sound level at 1 metre	dBa	75	75	75	75
Net Weight	kg	920	1100	2100	2500
Height H		1790	1402	1885	2085
Width L	mm	1590	1952	2170 / 3875	2170 / 3870
Depth P		2950	5213	5025	5244

GIRBAU S.A. reserves the right to change design and/or specifications without notice.

FT-LITE

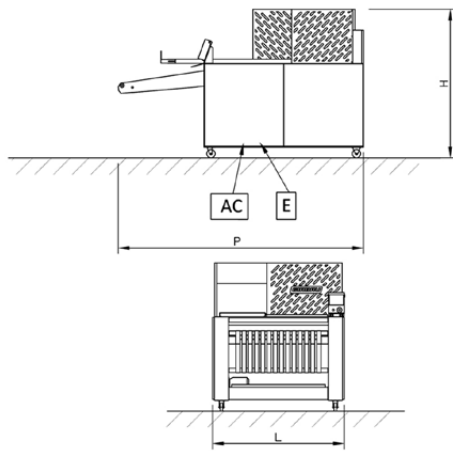

FT-MAXI

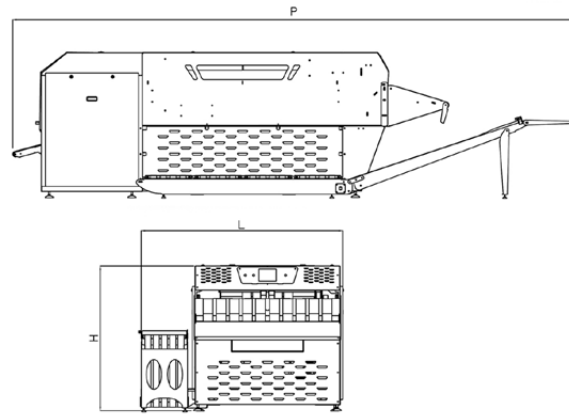

FT-POLY

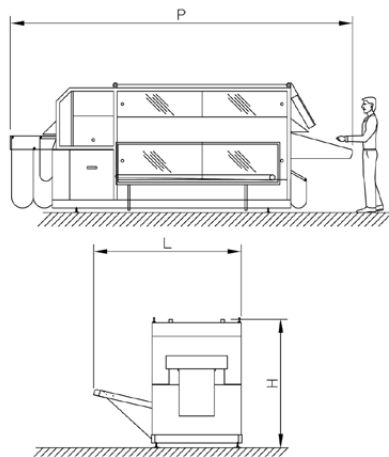

FT-VEST

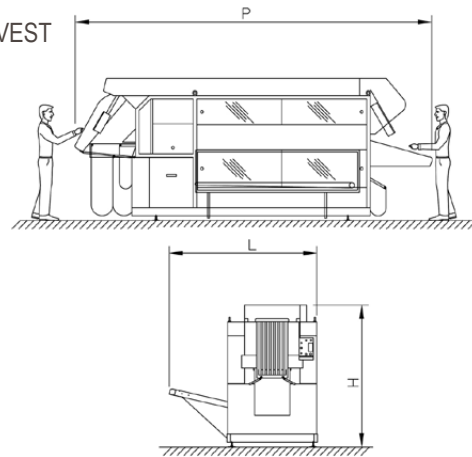

BRANCHES

Argentina - Buenos Aires - Tel. +54-1 149017600 - girbauargentina@girbau.com.ar
 Australia - Castle Hill, Sydney - Tel. +61298940399 - sales@girbau.com.au
 Brazil - Sao Paulo - Tel. +55 11-29820446 - girbaudobrasil@girbau.com.br
 China - Shenzhen & Hong Kong - Tel. +86-755-8211 1330 - info@girbau.com.cn
 Cuba - La Habana - Tel. (+53-7) 8662071 al 73 - girbau@girbau.co.cu
 Dominican Rep. - Punta Cana - Tel. +1 809-959-0615 - info@girbau.do
 France - Roissy (Paris) - Tel. +33 1-49388585 - info@girbau.fr
 Germany - Hannover - Tel. +49-511 60099389 - girbau@girbau.de
 Italy - Marcon (VE) - Tel. +39 0418654330 - info@girbau.it
 Portugal - Porto - Tel. +351 22 3758909 - vendasportugal@girbau.pt
 U.A.E. - Dubai - Tel. +971 4-8839951 - sales@girbau.ae
 U.K. - Hitchin - Tel. +44(0)-1462 427780 - info@girbau.co.uk
 U.S.A. - Oshkosh, WI & Los Angeles, Ca - Tel. +1(920) 2318222 - info@continentalgirbau.com

HEADQUARTERS

GIRBAU, S.A. Ctra de Manlleu, km. 1 - 08500 Vic (Barcelona) Spain - www.girbau.com
 Tel. (+34) 93 886 2219 - Fax (+34) 93 886 0785 - sales@girbau.es

